



ASSOCIAZIONE IMPRESE ITALIANE
DI STRUMENTAZIONE

Applicazioni analitiche per le misure e sicurezza negli impianti Idrogeno

12 Settembre 2024

Piacenza

Paolo Gaiti, Emerson Sales Manager Systems



Hydrogen Chain

Production

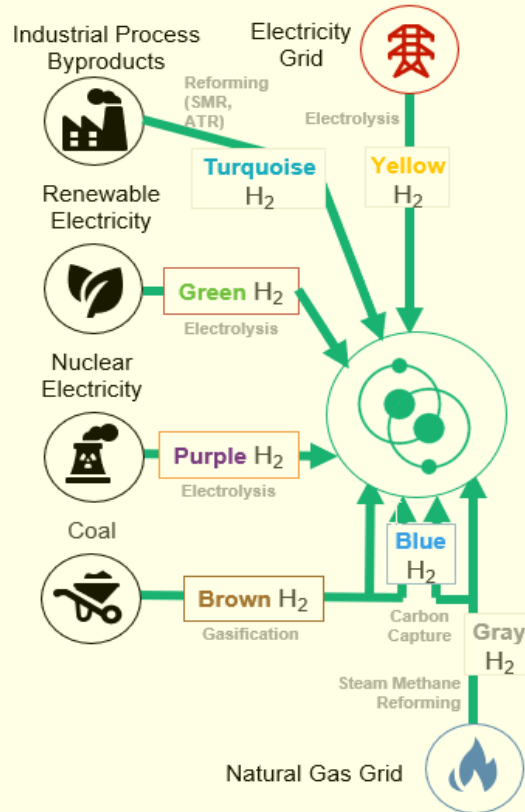

Transport & Storage

Transport

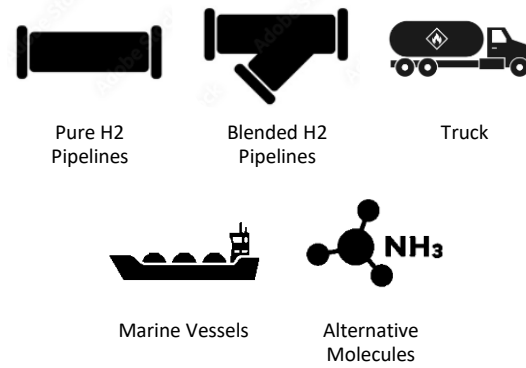

Storage

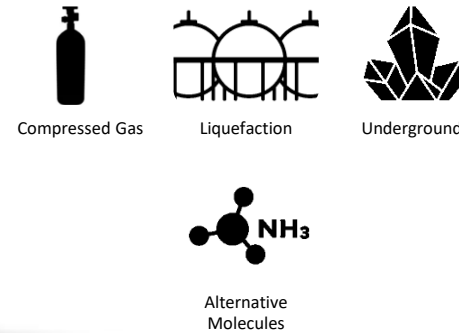

Utilization

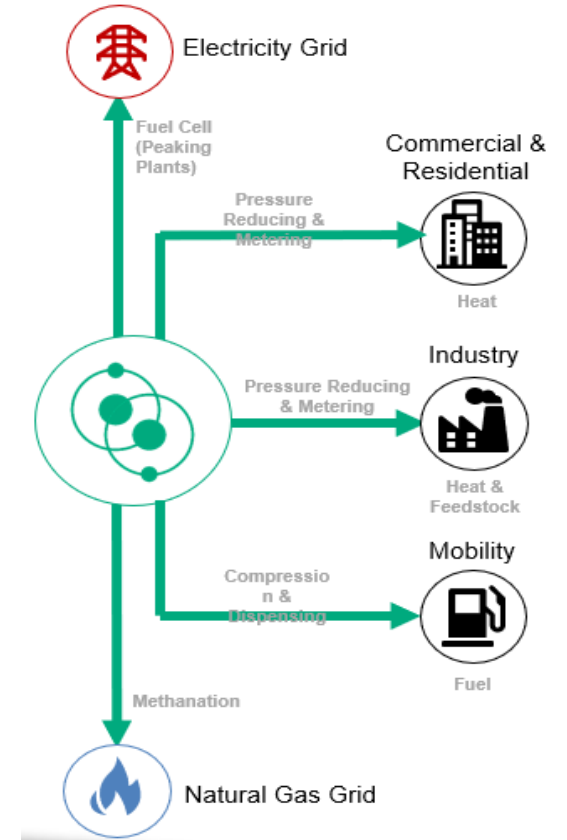

Production

Temperature Measurement



Pressure Measurement



Gas Analysis



Gas & Flame Detection



Flow Measurement



Rosemount Permasense Ultrasonic Sensors



Transportation

Wireless Pressure Transmitter



Coriolis Meters



Temperature Transmitter



Ultrasonic Flow Meters



Gas Chromatograph



Ultrasonic Corrosion Sensors



H2 Utilization

High-Pressure Coriolis Flow Meter



X-STREAM Gas Analyzer



Temperature Transmitter



High-Pressure Measurement



Incus Ultrasonic Gas Leak Detection & Flame Detection



Specific Gravity Meter



Rosemount Process Gas Chromatograph

- Designed for optimum reliability and flexibility
- Provides extended gas composition analysis with remote operation capabilities in an explosion-proof, field-mountable design

Rosemount X-STREAM Enhanced Gas Analyzer System

- Complete solution for traces of pollutant in H₂
- Sample gas cooler for water removal ensures accurate measurement of H₂
- IR, UV, TCD, E-chem, tO₂, tH₂O etc
- Process analyzer with auto-calibration/validation feature

Rosemount Cascade

- Quantum Cascade Technology
- Superior Accuracy & Reliability Measures up to 12 gases simultaneously and designed for Hydrogen
- Engineered Sample Handling Systems
- Designed to meet the application's specifications and rigorously tested for accuracy
- QCL
- Modbus TCP/IP communication and remote access through web browser

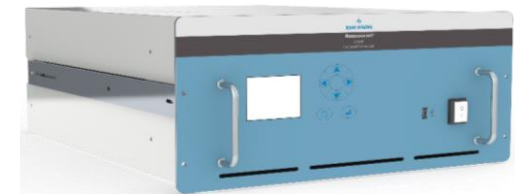

H₂ Value Chain For Flame and Gas Detector

PRODUCTION

CONVERSION, STORAGE & TRANSPORTATION

UTILIZATION



Flame Detection – **Hydrogen** fires are nearly invisible, if you have a leak from your process and it finds a source of ignition then this fire could burn for a long time before being noticed by conventional means -



Point Gas Detection – **Hydrogen** can very easily leak from a process, should this happen then this leak will not easily be noticed - Hydrogen has no odour and no colour and does not accumulate in external applications. **For internal applications**, the Meridian gas detector is the only electrochemical Hydrogen detector available that can detect 0-100% LEL of Hydrogen -



Ultrasonic Gas Leak Detection – **Hydrogen** can very easily leak from a pressurised process, should this happen then this leak will not easily be noticed - Hydrogen has no odour and no colour. **For internal and external applications**, using our Ultrasonic gas detection technology means you can easily detect the sound of Hydrogen leaking from a process -



Open Path Gas Leak Detection – **Ammonia** can be used a carrier gas for Hydrogen for storage and transportation purposes, Ammonia is then processed to create Hydrogen at the point of use. High and low concentrations of Ammonia are toxic and must be detected in the event of a leak. **For internal and external applications**, we recommend using our Open Path gas detection technology



Point Gas Detection – **CO₂** is a by-product created when natural gas or coal is the feedstock used to create Hydrogen. CO₂ has no odour and no colour but is very toxic and must be detected in the event of a leak. **For internal and external applications**, we recommend using the CO₂ detector to detect CO₂ leaks- ***FUTURE PRODUCT**



Open Path, Point Gas HC, Flame and Ultrasonic Detection – **Natural gas or coal** can be a feedstock for manufacturing Hydrogen. A high concentration of natural gas is explosive and must be detected in the event of a leak. **For internal and external applications**, we recommend using Open Path, Point Gas, Flame and Ultrasonic detection technologies -

Stage used



Production

Hydrogen Production

Hydrogen is produced from various sources through different processes.

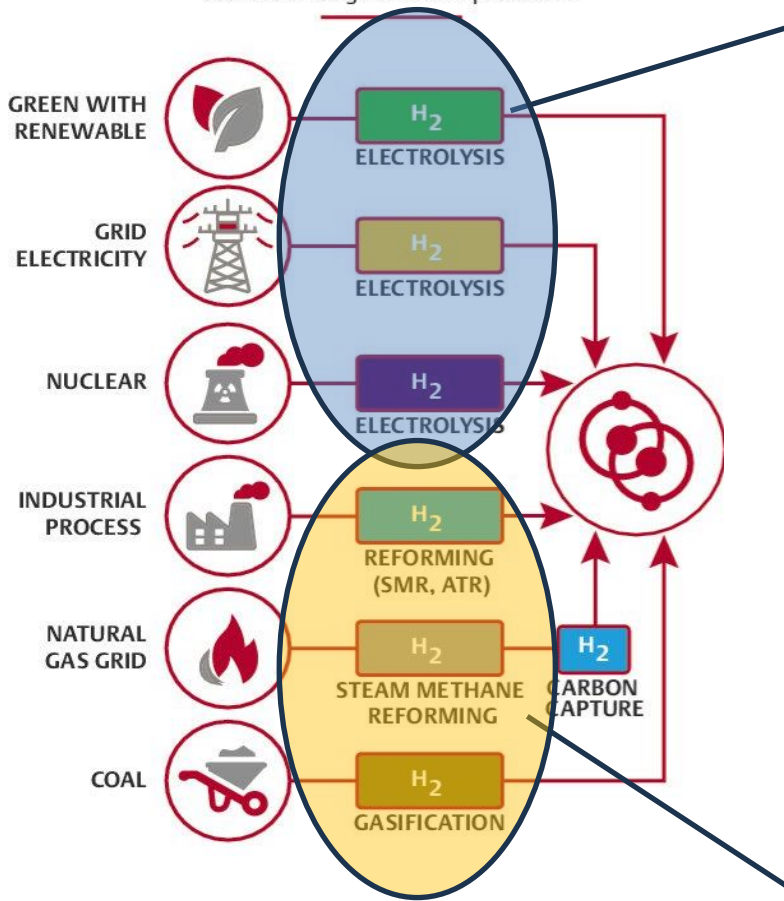

Electrolyzers

Steam Reforming & Gasification

Alkaline

Most mature technology
 Lowest CAPEX, no exotic materials
 Lowest efficiency
 Uses KOH as the electrolyte

PEM

Polymer membrane instead of liquid electrolyte
 More expensive due to rare earth minerals needed (Ti, Pt, Ir, Au)
 Higher efficiency reduces OPEX
 Smaller footprint, faster startup

AEM

This is the latest technology with only a few companies commercializing it
 AEM use a membrane like that of PEM but also have KOH in much lower concentrations of KOH (1% vs 20-30%) to transport the OH ions like an alkaline
 AEM materials are less expensive (Ni electrodes)

SOEC

Reverse capabilities- Can operate as fuel cell and electrolyzer
 These operate at high (700-850°C) temperatures using steam instead of water
 SOECs are today very new but projects are moving forward especially when near waste steam streams or nuclear power plants
 Very efficient up to 90%

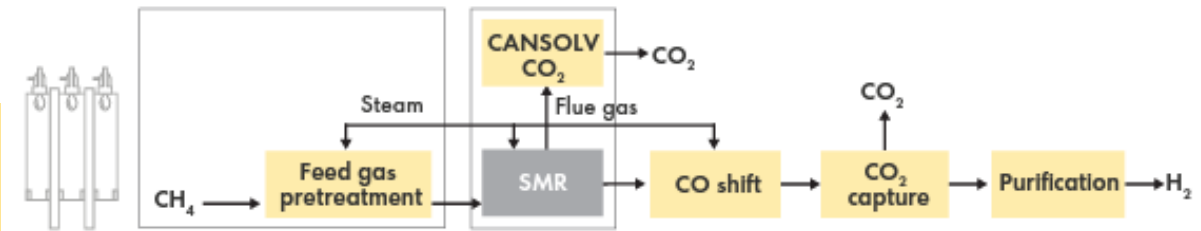

Electrolyser Types

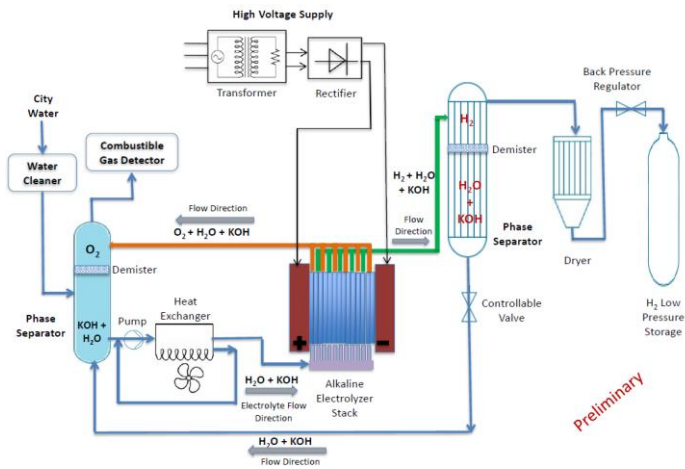

Alkaline Process

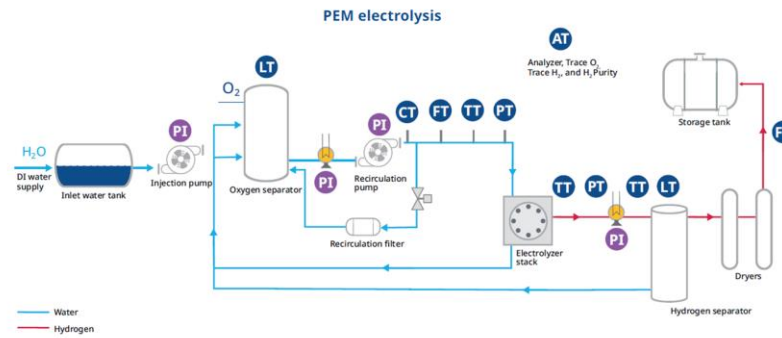

PEM Process

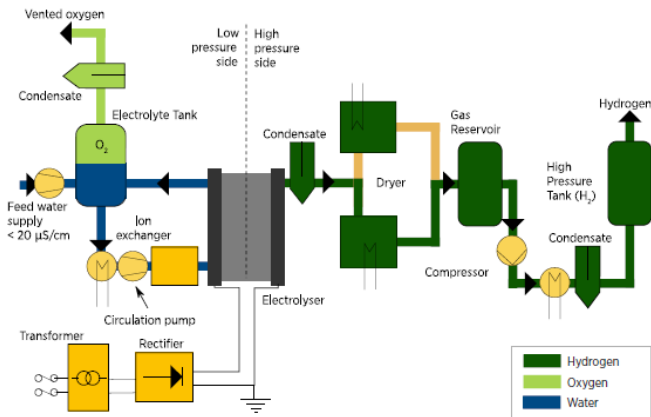

AEM Process

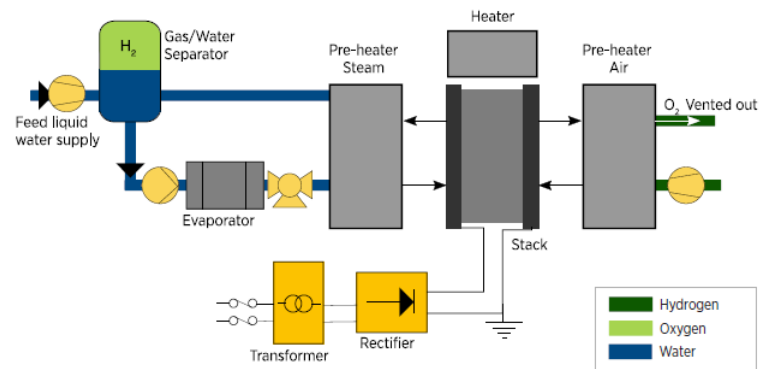

SOEC Process

Liquid Analytical



Rosemount 3900 General Purpose pH/ORP Sensor



Rosemount 400 Conductivity Sensor

Gas Analytical

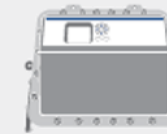

Rosemount X-Stream Enhanced Continuous Gas Analyzer

Safety Flame & Gas



Rosemount 975 Flame Detector



Rosemount 625IR Point or duct Gas detector



Rosemount Incus Ultrasonic Gas Leak Detector

Analytical Solutions for SMR (steam methane reforming)

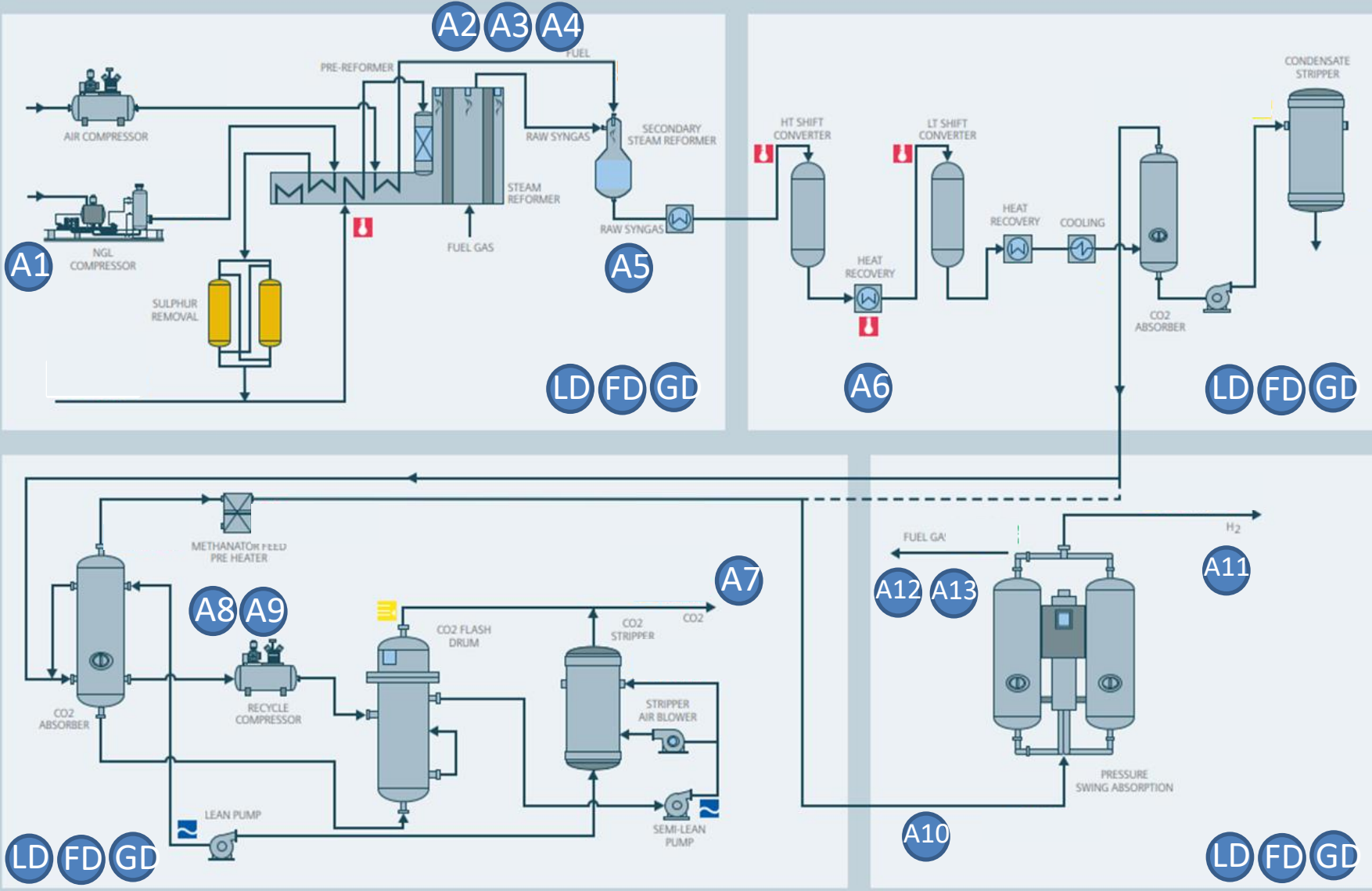

- A1** Analysis C1, C2, C3, C4, C5, C6+, N2, CO2
- A2** Analysis CO & O2 (Combustion)
- A3** NH3 (SCR / SNCR)
- A4** CEMS O2, CO, CO2, NOx, SOx, CH4
- A5** Syngas H2, CO, CO2, CH4
- A6** Shift Converter H2, CO
- A7** Purity CO2 CO, N2, CH4
- A8** Inlet cold box CO2, H2O
- A9** Product CO H2, CH4, N2
- A10** Outlet cold box CO, H2
- A11** Product H2 (PSA) CO, CO2, CH4, (other impurities)
- A12** PSA Tail gas H2, CH4, CO, BTU
- A13** Reformer fuel Gas BTU
- LD FD GD** Leak Detection, Flame Detection, Gas detection

Steam Reforming – Process Description

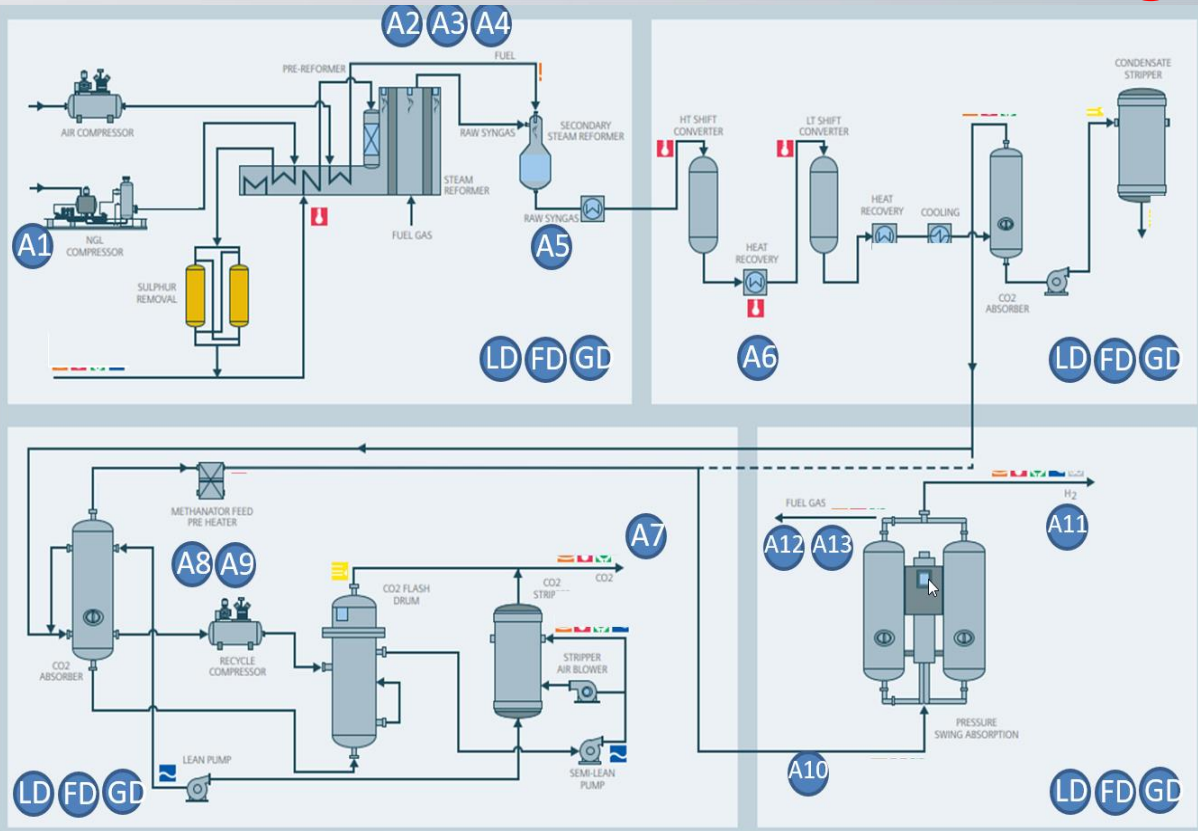

- A1** Analysis C1, C2, C3, C4, C5, C6+, N2, CO2
- A2** Analysis CO & O2 (Combustion)
- A3** NH3 (SCR / SNCR)
- A4** CEMS O2, CO, CO2, NOx, SOx, CH4
- A5** Syngas H2, CO, CO2, CH4
- A6** Shift Converter H2, CO
- A7** Purity CO2 CO, N2, CH4
- A8** Inlet cold box CO2, H2O
- A9** Product CO H2, CH4, N2
- A10** Outlet cold box CO, H2
- A11** Product H2 (PSA) CO, CO2, CH4, (other impurities)
- A12** PSA Tail gas H2, CH4, CO, BTU
- A13** Reformer fuel Gas BTU

LD FD GD Leak Detection, Flame Detection, Gas detection

Combustion



A2 Rosemount OCX and OXT O2/CO analyzer

Gas Analytical



Rosemount X-Stream Enhanced Continuous Gas Analyzer

A3 A5 A6 A7 A10 A11



Rosemount 700XA Process Gas Chromatograph

A1 A11 A12



Rosemount QCL Quantum Cascade Laser

A4 A8 A9 A13

Flame & Gas



Rosemount 975 Flame Detector

FD



Rosemount 936 Open Path Gas Detector System

GD



Rosemount 625IR Point or duct Gas detector

GD



Rosemount Incus Ultrasonic Gas Leak Detector

LD

Hydrogen Chain

Production

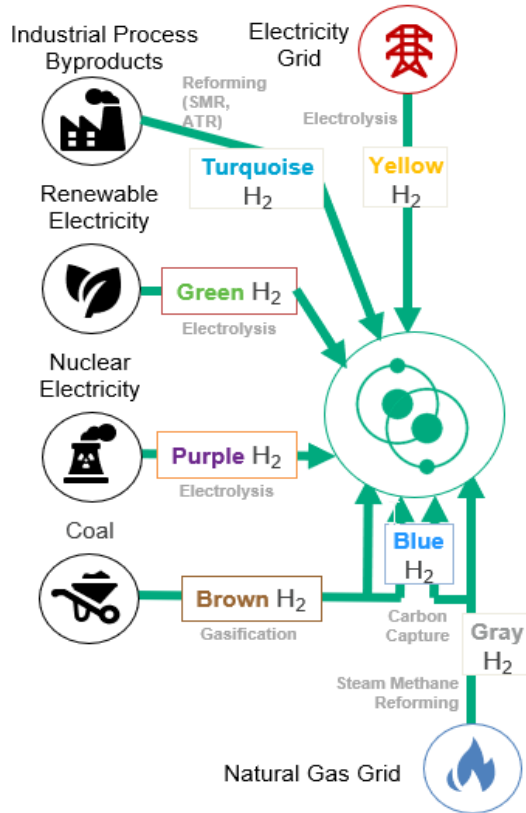

Transport & Storage

Transport

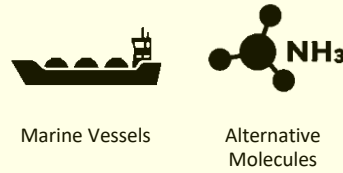

Storage

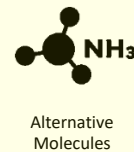
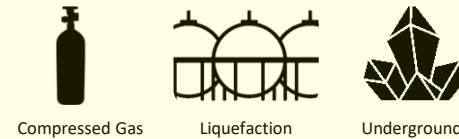

Utilization

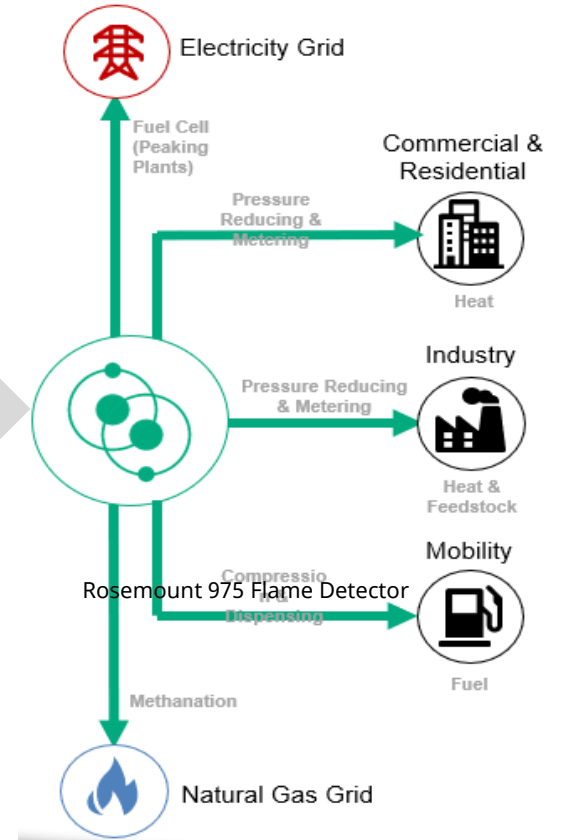

Custody Transfer for Pure Hydrogen

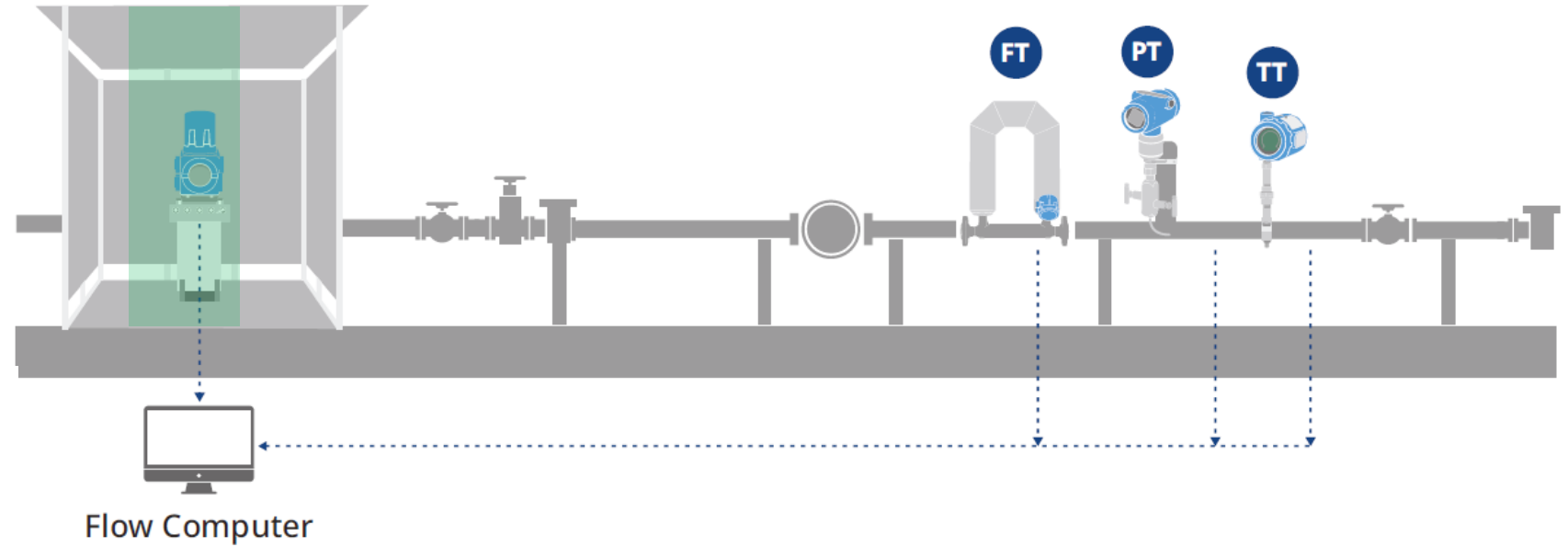
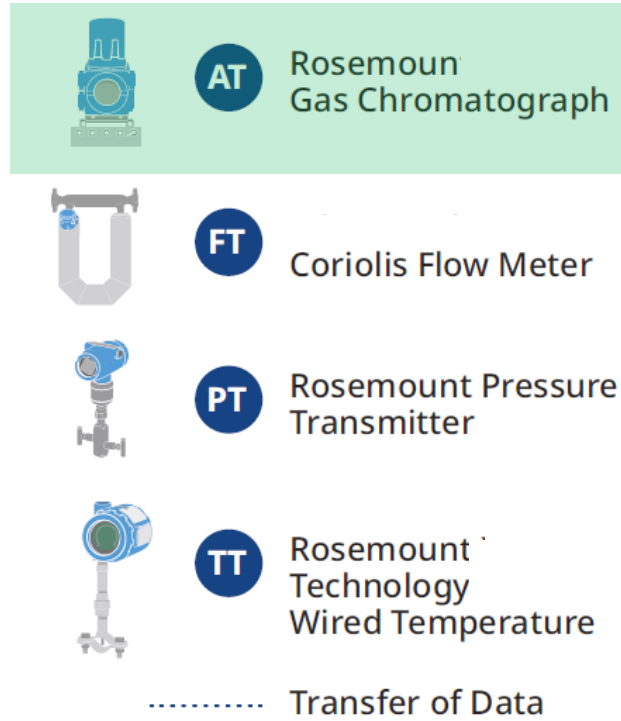

Representative Emerson engineered solution for custody transfer.

Truck Loading / Unloading



FT

Coriolis (HPC) Series Meter



FD

Rosemount Multi-Spectrum Infrared Hydrogen Flame Detector



UGLD

Rosemount Incus Ultrasonic Gas Leak Detector

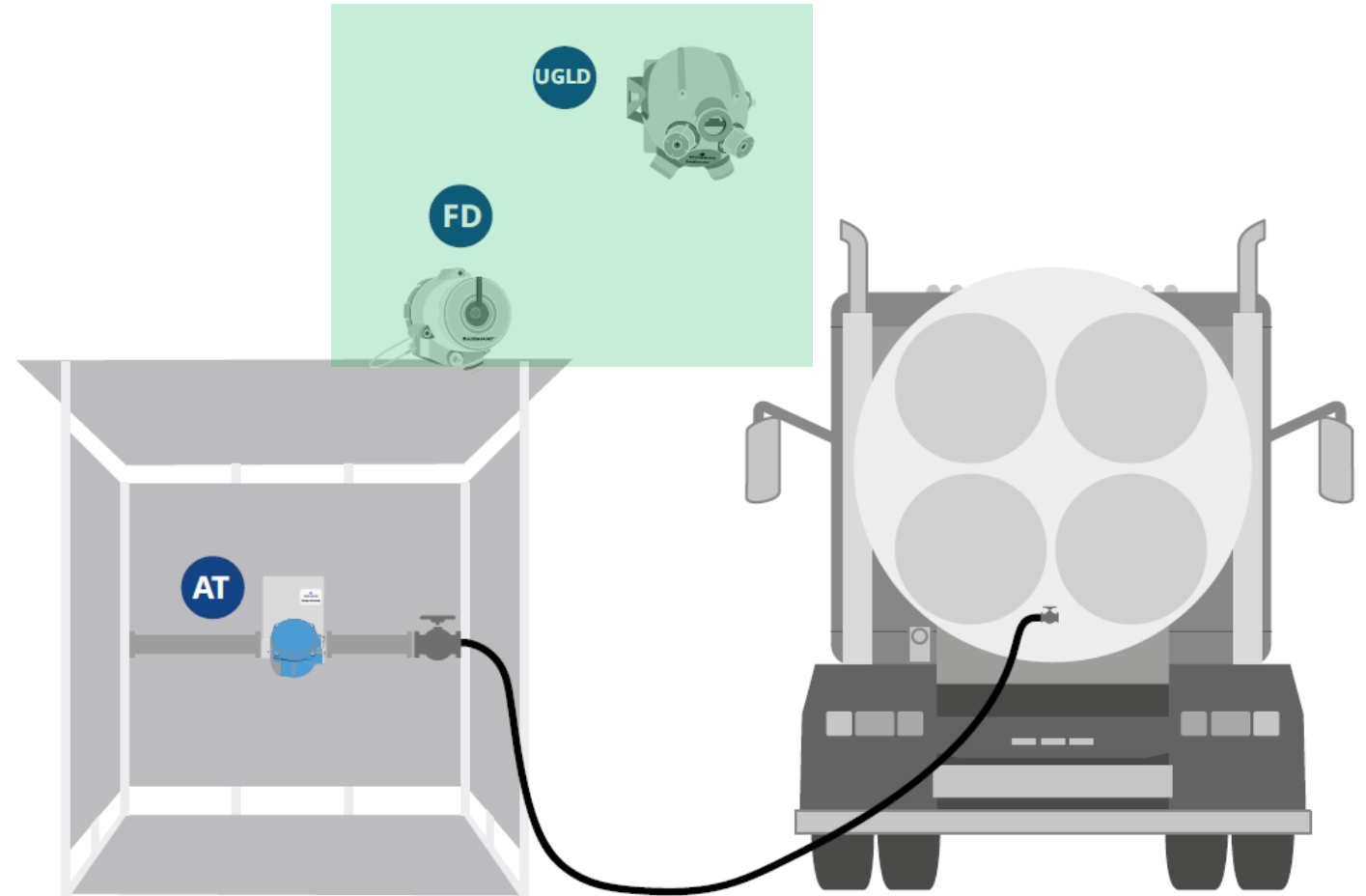

Hydrogen Storage

Compressed Gas

Liquefaction

Underground caverns

Alternative Molecules

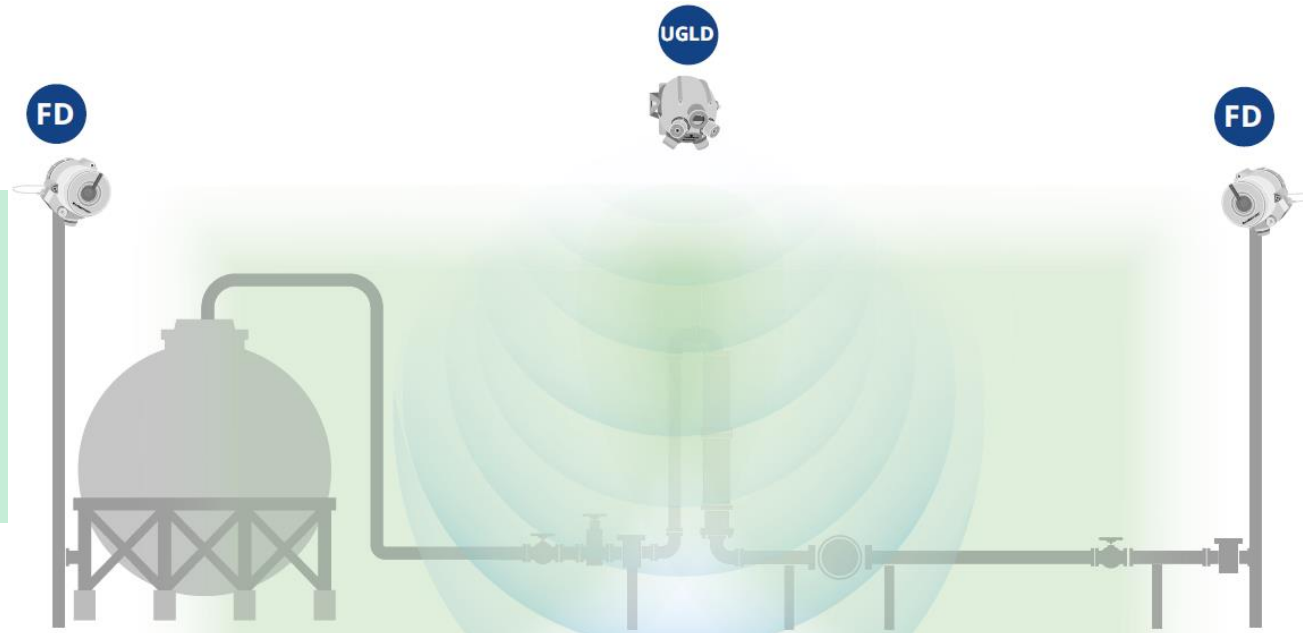

FD Rosemount Multi-Spectrum Infrared Hydrogen Flame Detector

UGLD Rosemount Ultrasonic Gas Leak Detector



Hydrogen Chain

Production

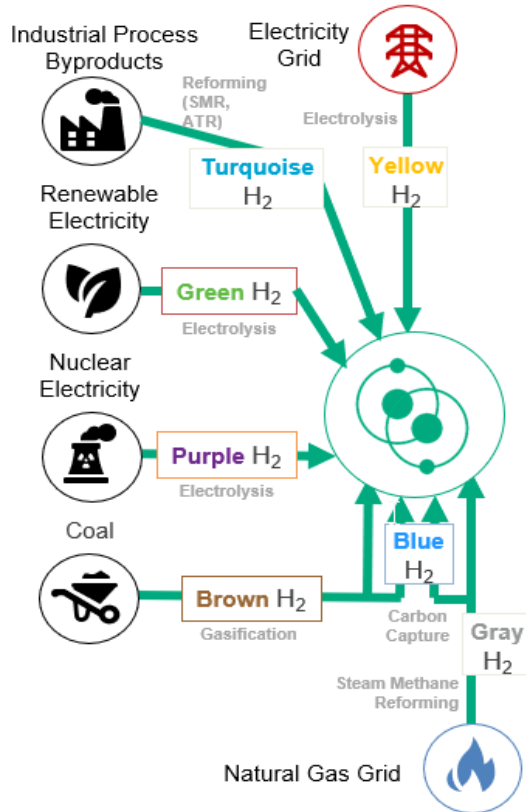

Transport & Storage

Transport

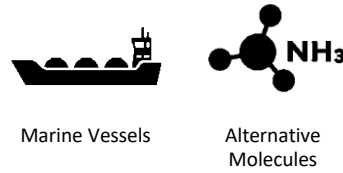

Storage

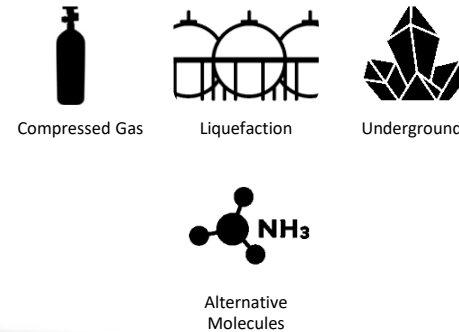

Utilization

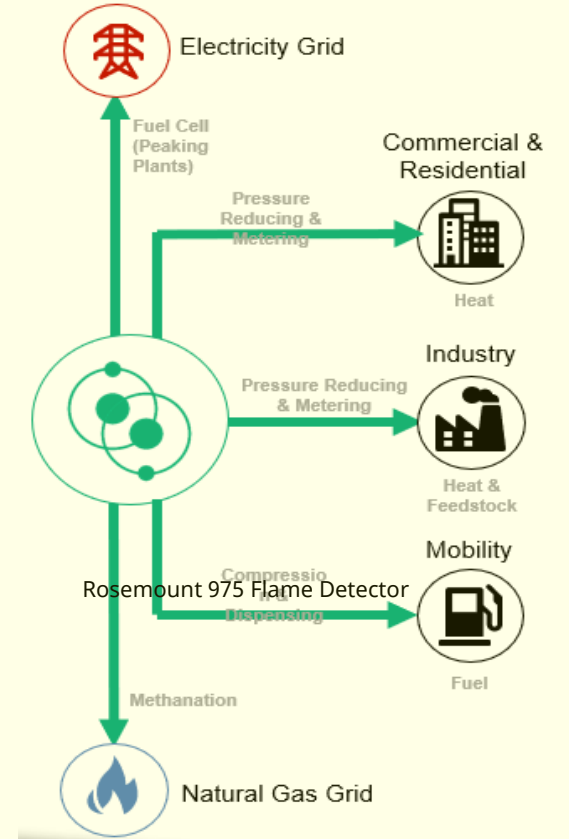

Hydrogen Injection/ Blending



AT Gas Chromatograph



FT1 Coriolis Flow Meter



FT2 Flexim

or



Ultrasonic Gas Flow Measurement

or



Coriolis Flow Meter

..... Transfer of Data

— 95% Pure H₂

— Natural Gas Pipeline

— H₂ Blended Natural Gas <30% H₂

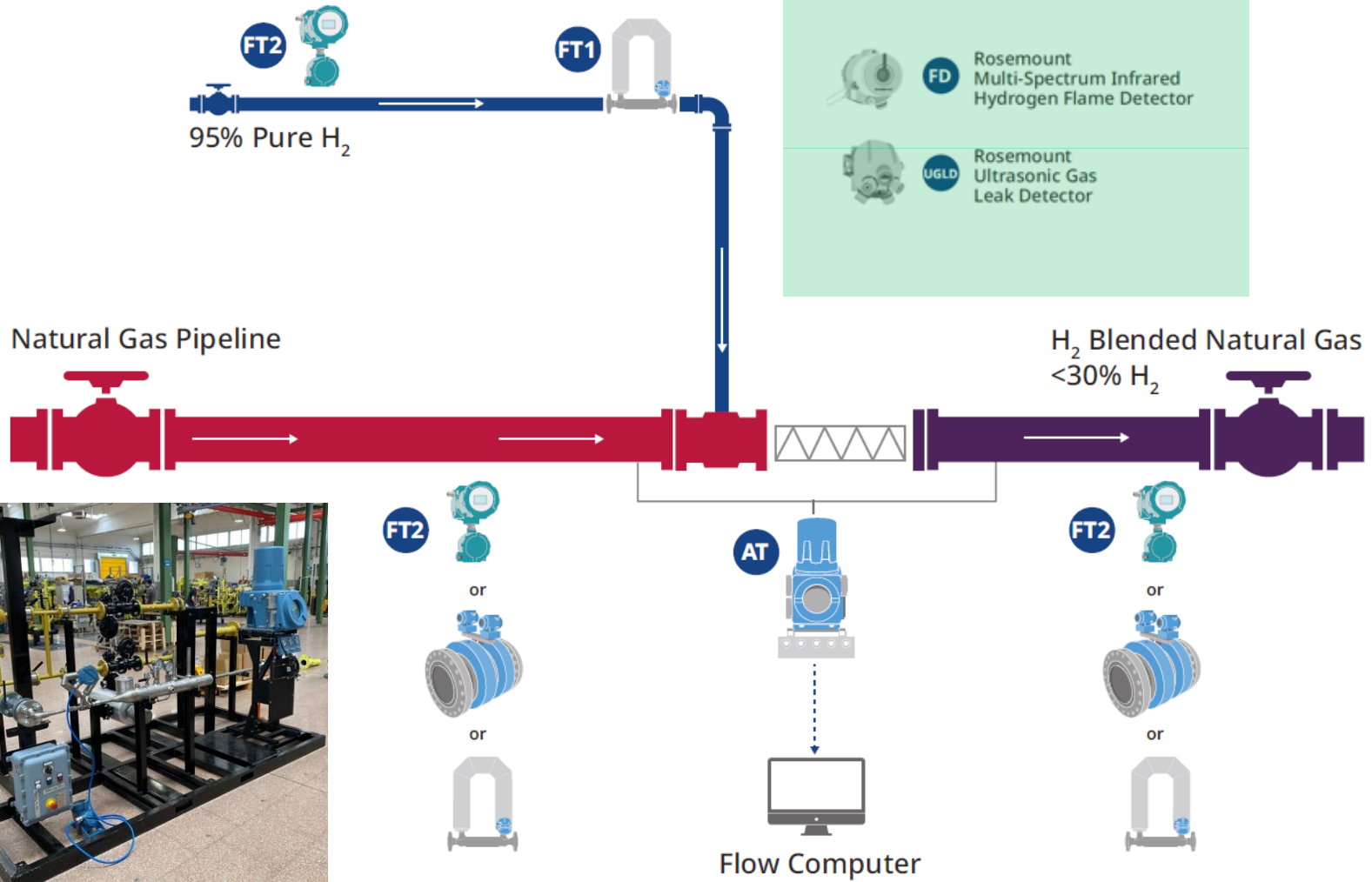

Hydrogen injection station

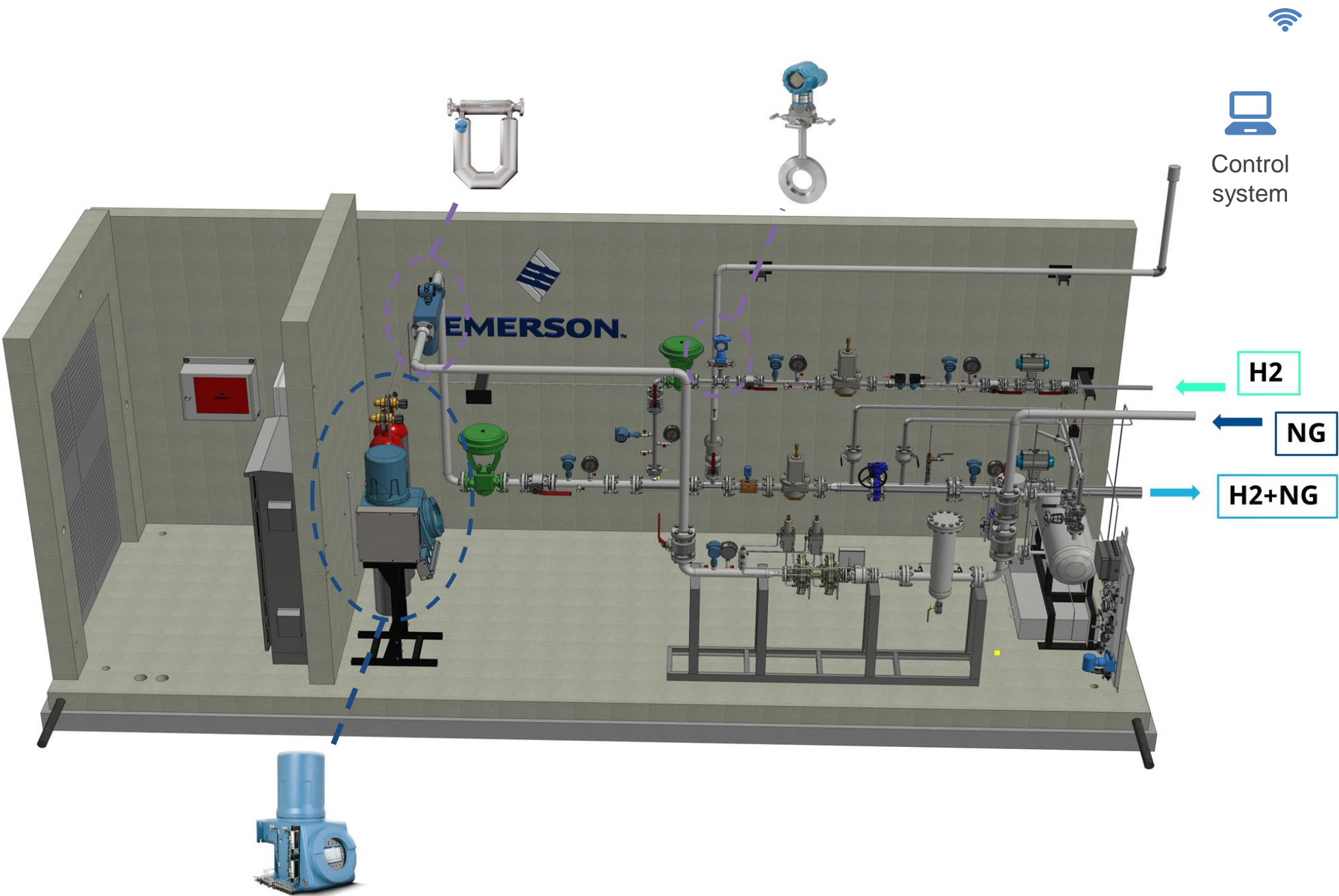

Pressure & Flow Control

Overpressure Protection

Gas Analysis

Gas Measurement

Odorant injection

Control Systems

Smart Technologies

*Grazie per la Vostra
partecipazione e attenzione*



ASSOCIAZIONE **IMPRESE ITALIANE**
DI **STRUMENTAZIONE**